

ELECTRONICS REGIONAL TEST LABORATORY (WEST)		REPORT NO.	
MINISTRY OF COMMUNICATIONS AND INFORMATION TECHNOLOGY (STQC DTE)		ERTL (W)/ 2004EMI 347	
SUBJECT: EMC TESTING ON AC VOLTAGE TRANSDUCER		DATE	PAGE OF
			1 4

7 DEC 2005

1. SCOPE

1.1 Service Request No ERTL (W)/2005 / 20051975

1.1.1 Service Request finalised on 10-NOV-2005

1.2 Requested by MECO INSTRUMENTS PVT.LTD.

(Name and address of manufacturer) 301, BHARAT INDL. ESTATE,
T.J. ROAD, SEWAREE,
MUMBAI - 400 015

1.3 Item No.	Description	Qty	Manufacturer	Type No.	Sr. No.
1.	AC VOLTAGE TRANSDUCER	01	MECO INSTRUMENTS PVT.LTD.	VMT	055486

1.4 Test specifications IEC 61000-4-12 :2000.

1.5 Laboratory Ambient
1. Temp : 25 ± 2 °C
2. Humidity : 55 ± 5%

1.6 Test Equipment used:
1. Test generator (Schaffner NSG 505 HF)
2. Coupling network (Schaffner NSG 523)
3. Interference voltage distributor accessory (Schaffner)



ELECTRONICS REGIONAL TEST LABORATORY (WEST) MINISTRY OF COMMUNICATIONS AND INFORMATION TECHNOLOGY (STQC DTE)	REPORT NO. ERTL (W)/ 2004EMI 347		
SUBJECT: EMC TESTING ON AC VOLTAGE TRANSDUCER	DATE 17 DEC 2005	PAGE 2	OF 4

2.0 Equipment Under test (EUT) Description:

2.1 AC VOLTAGE TRANSDUCER finds application in industrial use.

2.2 Performance Function of Equipment under Test (EUT)

- Connect 230 V AC / 50 Hz single phase supply to Aux terminal.
- Apply input voltage 0 – 110 VAC on input terminal.
- Connect 0 - 500 ohms load resistor to output terminals.
- Measure output current on output terminals, it is between 4 - 20mA.

2.3 Functional check for all immunity tests.

Performance Criteria- 'A'

The EUT shall continue to operate as intended during and after the test . No degradation of performance or loss of function is allowed.

Performance Criteria –'B'

The EUT shall continue to operate as intended during and after the test . During the test, degradation of performance is however allowed. No change of actual operating state or stored data is allowed.

Performance Criteria – 'C'

Temporary loss of function is allowed , provided the function is self – recoverable or can be restored by the operation of the controls.



ELECTRONICS REGIONAL TEST LABORATORY (WEST)		REPORT NO.	
MINISTRY OF COMMUNICATIONS AND INFORMATION TECHNOLOGY (STQC DTE)		ERTL (W)/ 2004EMI 347	
SUBJECT: EMC TESTING ON AC VOLTAGE TRANSDUCER		DATE	PAGE
		7 DEC 2005	3
		OF	4

3.0 Test Results:

3.1 HIGH FREQUENCY DISTURBANCE.

Test Rationale:

To check oscillatory wave immunity requirements for Electrical/Electronic equipment connected to low voltage power supply.

a Test Condition:

Specification As per IEC 61000-4-12.
 Set-up As per IEC 61000-4-12.
Mode of simulation: Transverse (Differential mode) : 1 kV peak

Frequency: 1MHz Damped Oscillatory

Test level 3

Duration: 2 seconds

Application: On Aux. Terminal 230VAC main supply through CDN.

b EUT in normal operating condition.

c Test procedure:

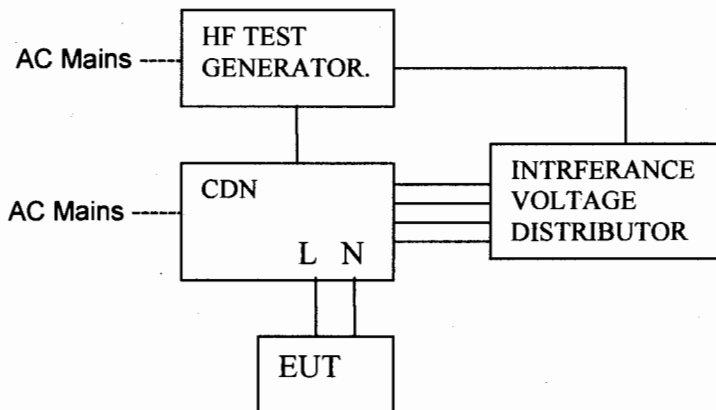

d Requirement:

Performance Criterion B, temporary degradation or loss of function is allowed during the test. After the test EUT shall function normal.

e Observations

Output of the EUT was found fluctuating during the test which was self recoverable and after the test it was functioning normal as per sr. no.2.2.

f Results

Complied (Meets Performance Criterion B)



ELECTRONICS REGIONAL TEST LABORATORY (WEST)		REPORT NO.	
MINISTRY OF COMMUNICATIONS AND INFORMATION TECHNOLOGY (STQC DTE)		ERTL (W)/ 2004EMI 347	
SUBJECT: EMC TESTING ON AC VOLTAGE TRANSDUCER		DATE	PAGE
		7 DEC 2005	4
		OF	4

4.0 General Remarks: Testing was carried out on 2/12/ 2005 at ERTL(W), MUMBAI

REPORT APPROVED BY

REPORT RELEASED BY

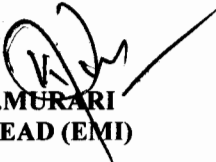
K.MURARI
HEAD (EMI)

